

Инструкция по сборке

Техас

Комод №11

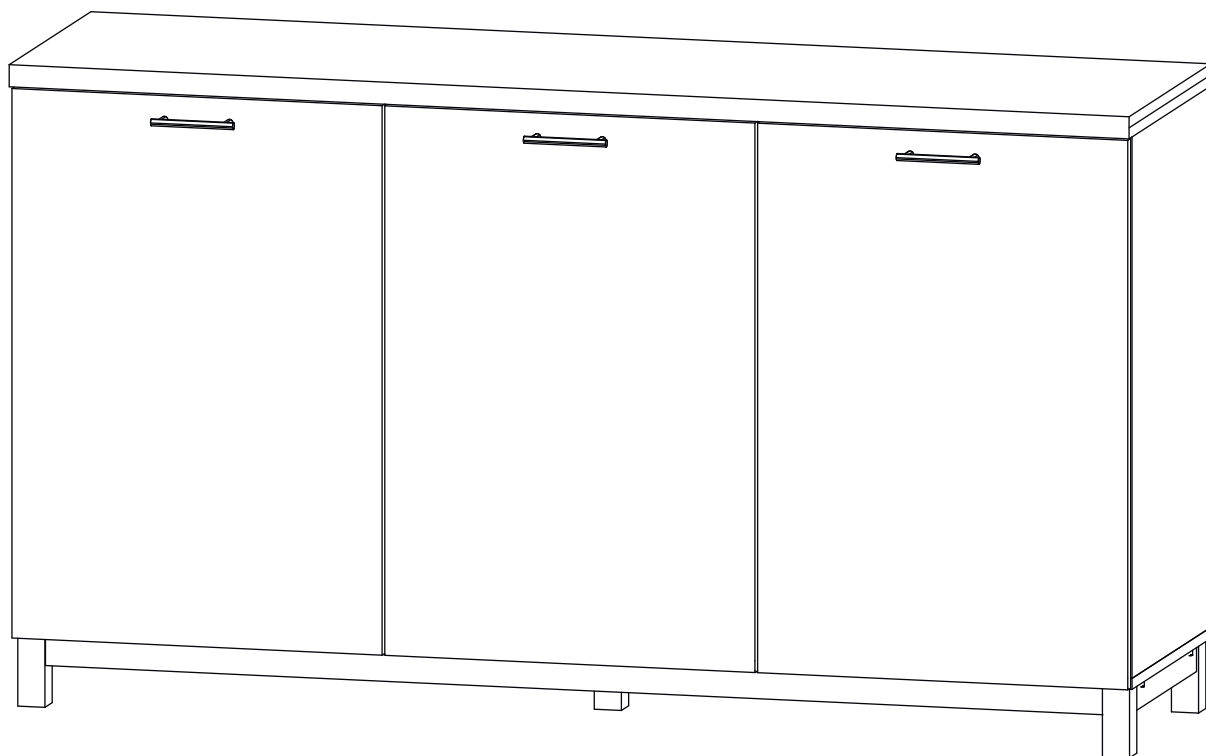



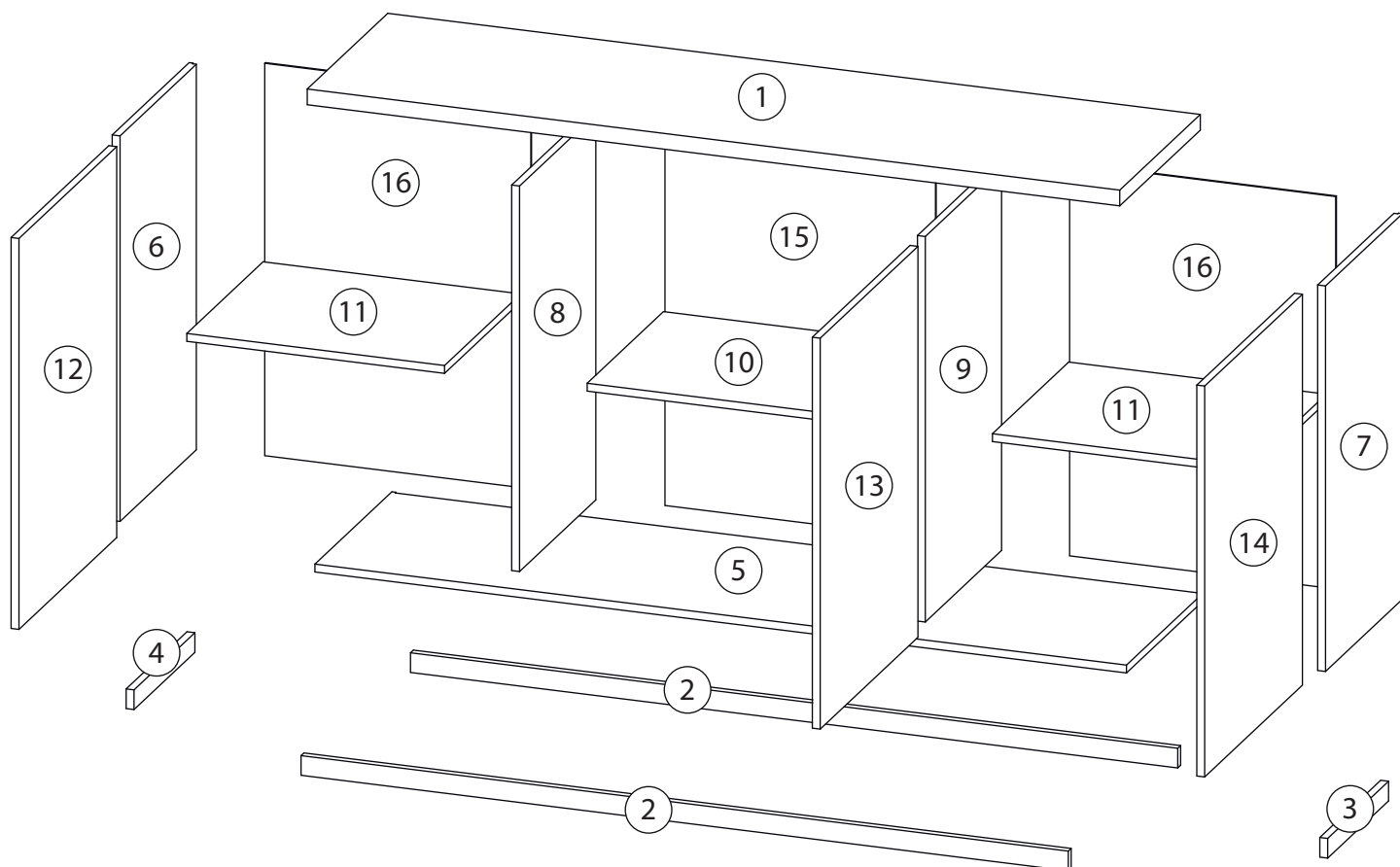

Детали

Поз.	Наименование	Кол-во	Длина	Ширина
1	Столешница	1	1652	450
2	Планка	2	1560	40
3	Планка	1	340	40
4	Планка	1	340	40
5	Дно	1	1650	430
6	Бок левый	1	784	430
7	Бок правый	1	784	430
8	Вертикаль	1	784	426
9	Вертикаль	1	784	426
10	Полка	1	534	426
11	Полка	2	524	426
12	Фасад	1	795	546
13	Фасад	1	795	546
14	Фасад	1	795	546
15	Задняя стенка	1	798	550
16	Задняя стенка	2	798	541

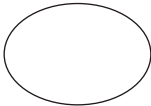
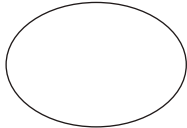
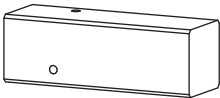
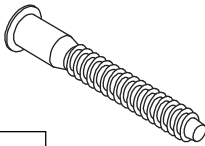
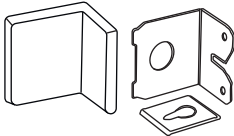

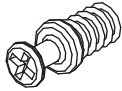
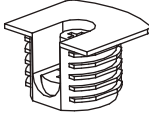
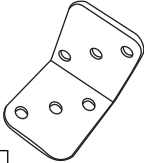
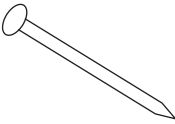
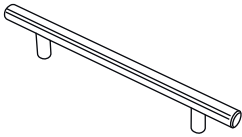
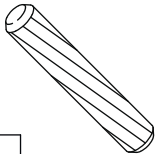
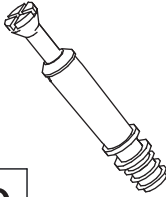
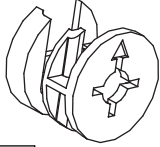
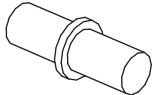
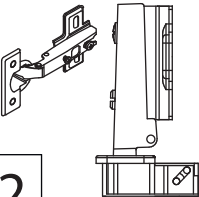
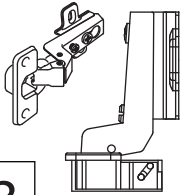
Фурнитура

				
17	18	19	20	21
<u>Заглушка</u> Ø13	<u>Заглушка</u> Ø17-20	<u>Опора</u>	<u>Евровинт 7x50</u>	<u>Крепежный уголок</u>
				
22	23	24	25	26
<u>Саморез 3,5x16</u>	<u>Винт для стяжки</u> VB35	<u>Стяжка VB35</u>	<u>Уголок</u>	<u>Гвоздь 1,6x25</u>
				
27	28	29	30	31
<u>Ручка</u>	<u>Шкант бук</u>	<u>Шток эксцентрика</u>	<u>Эксцентрик</u>	<u>Полкодержатель</u>
				
32	33	34		
<u>Петля накладная</u>	<u>Петля</u> <u>полунакладная</u>	<u>Евровинт 6,3x13</u>		

1

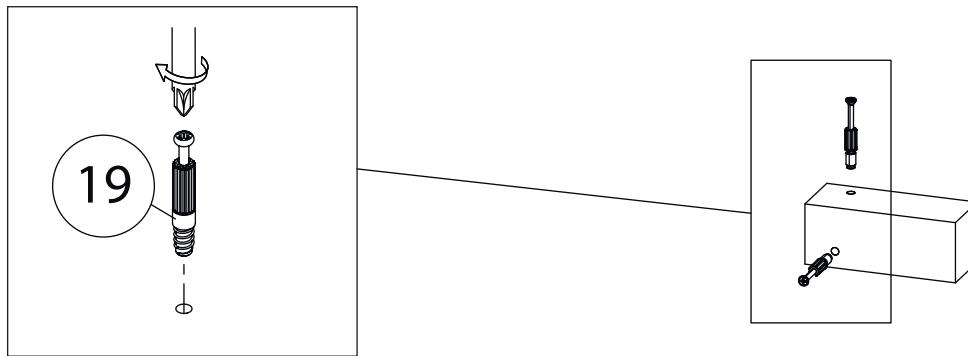

Остальные опоры
собирается аналогично.

2

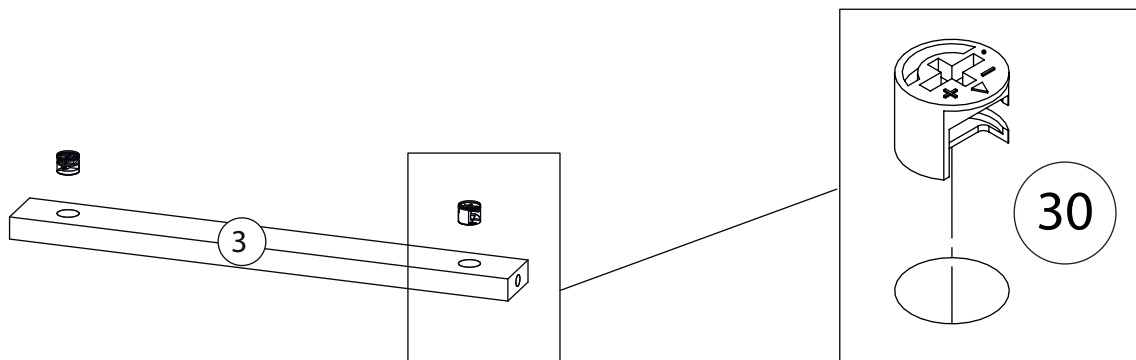

Планка (2,4)
собирается аналогично

3

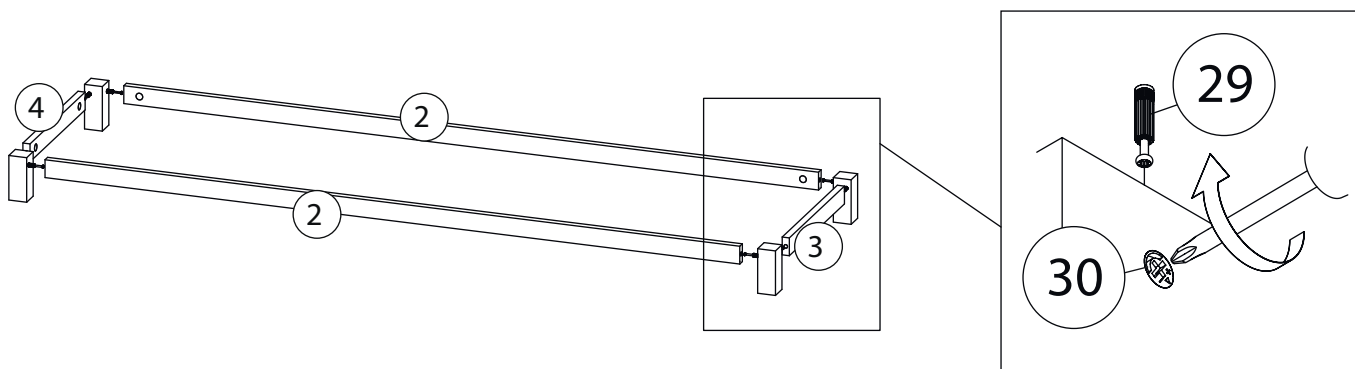

4

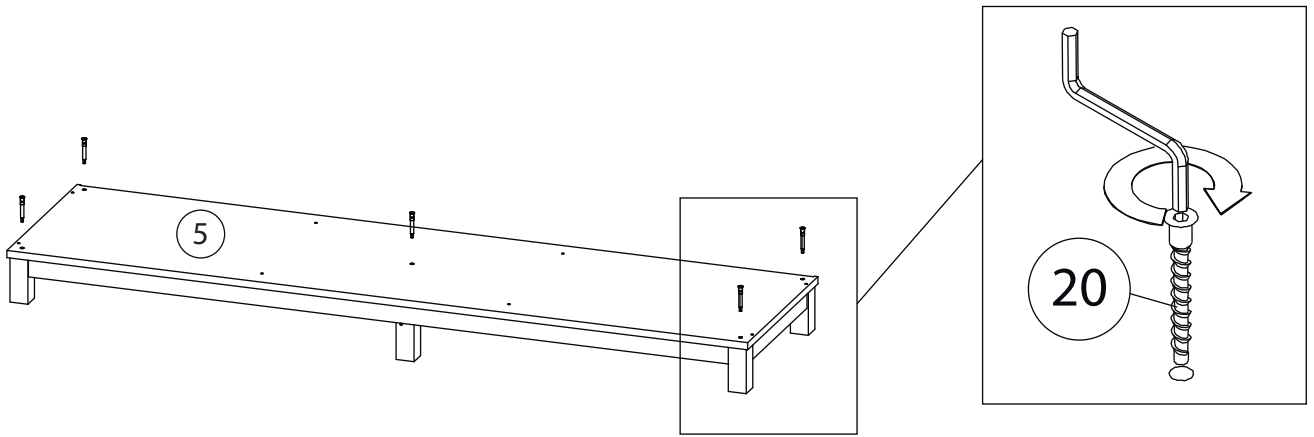

5

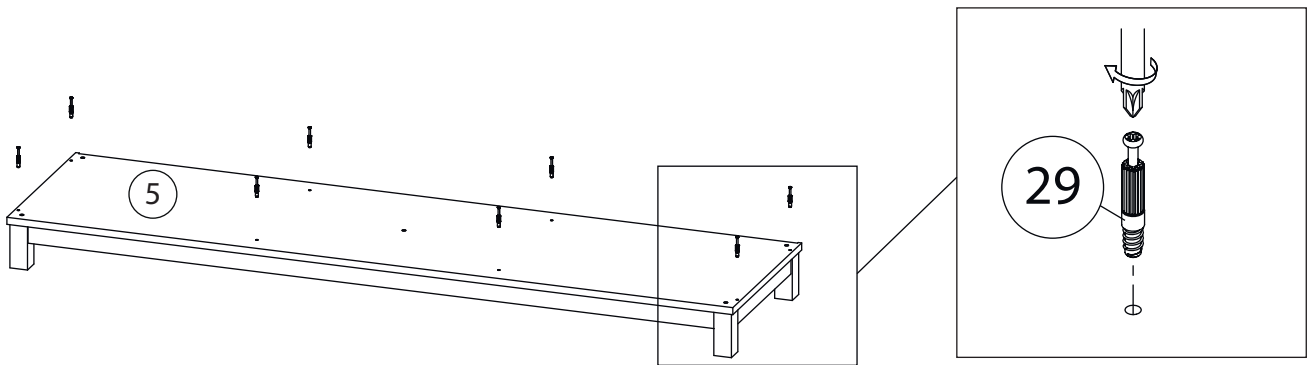

6

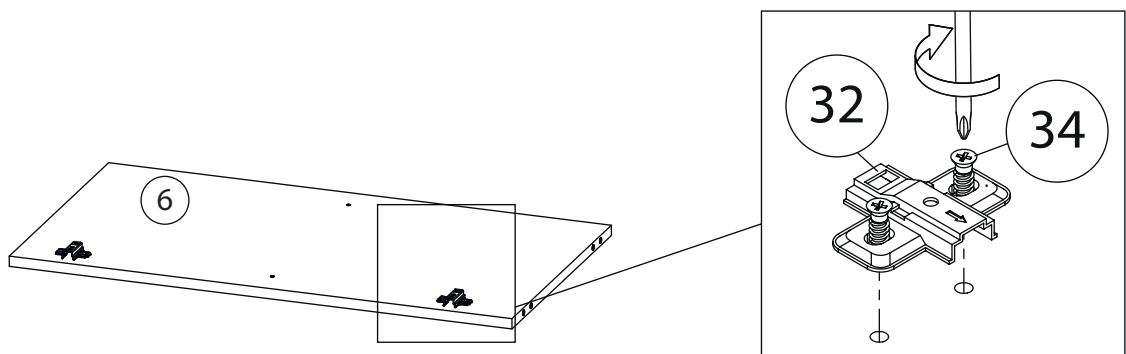

7

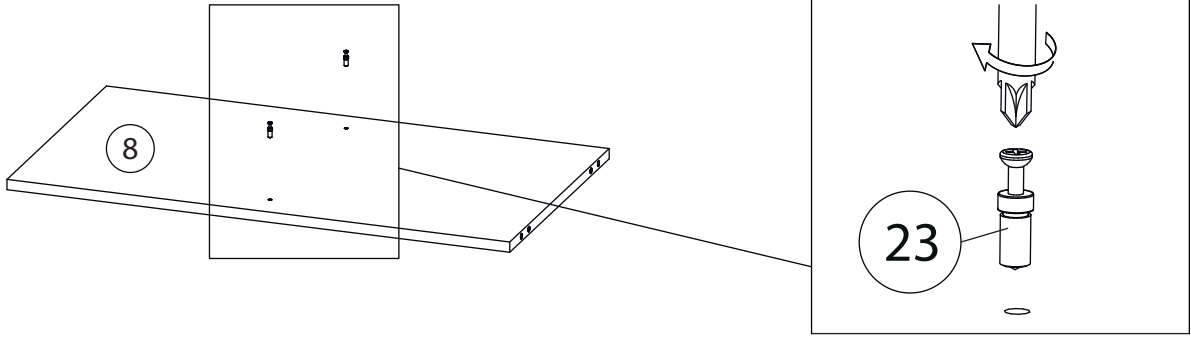

8

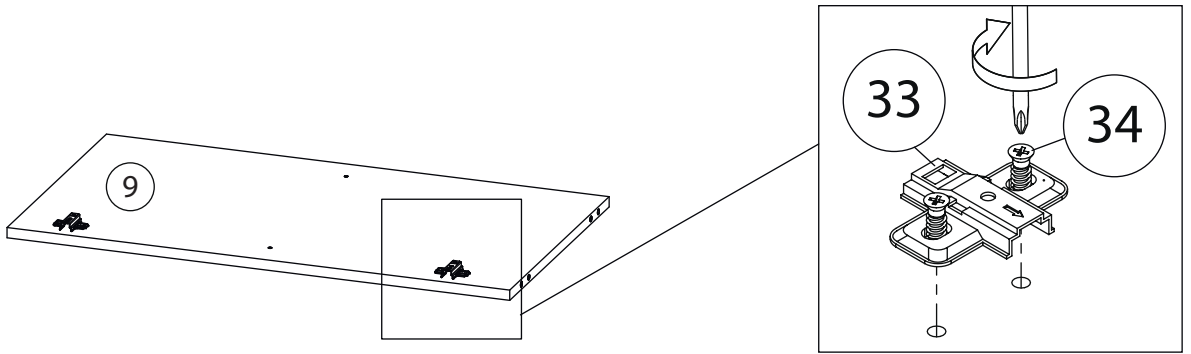

9

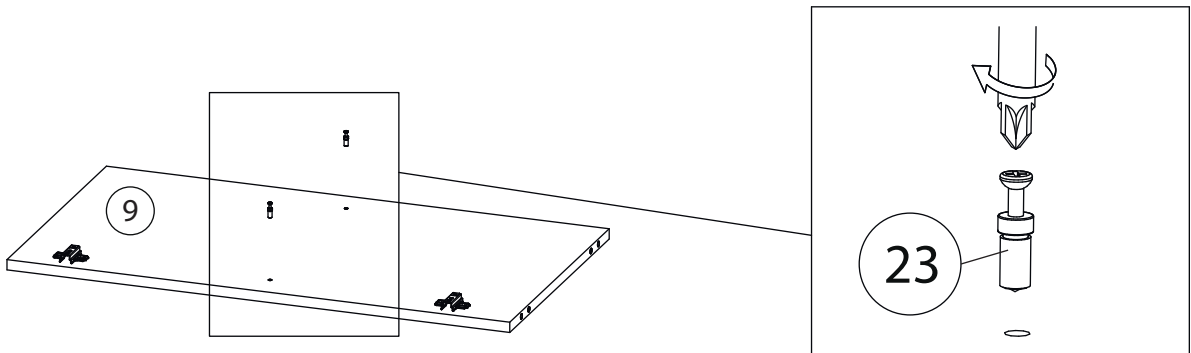

10

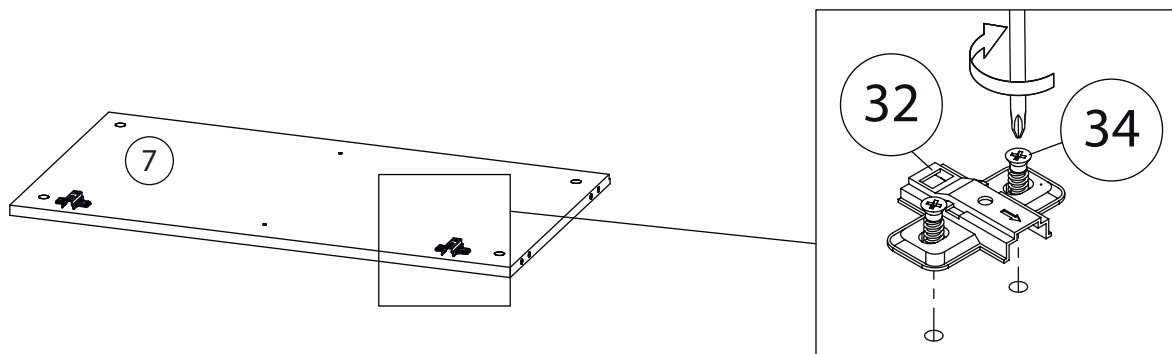

11

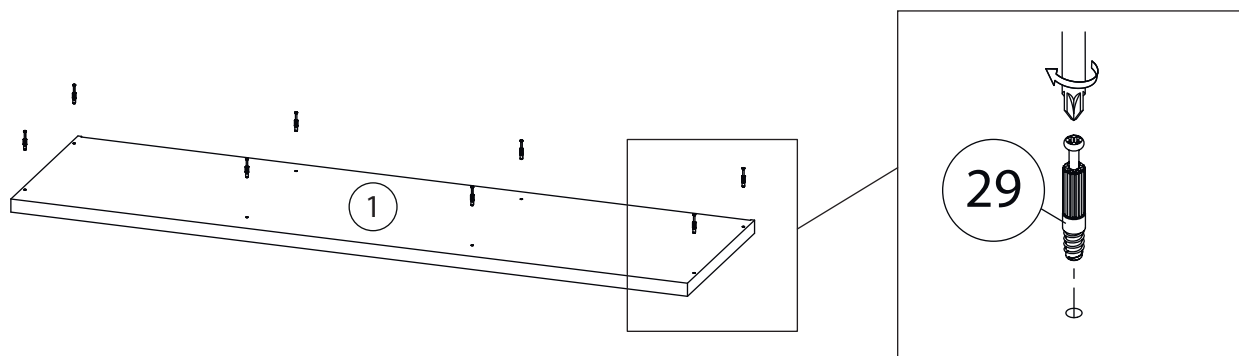

12

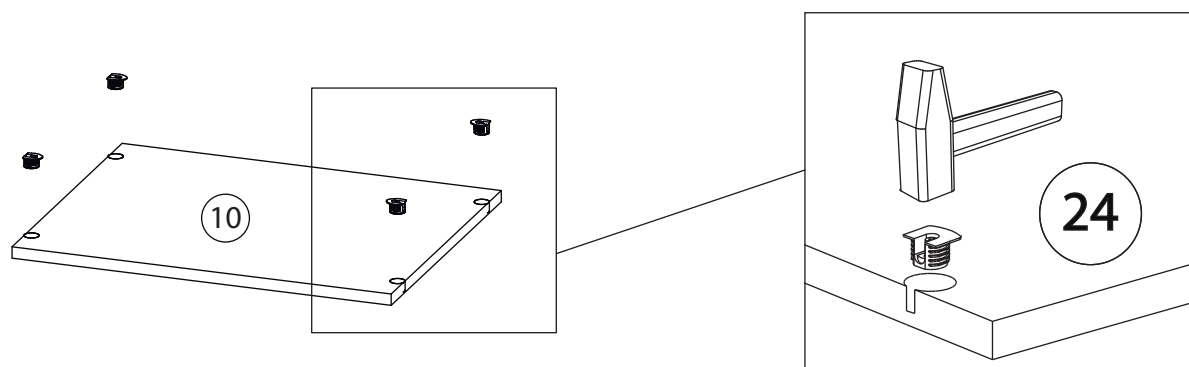

13

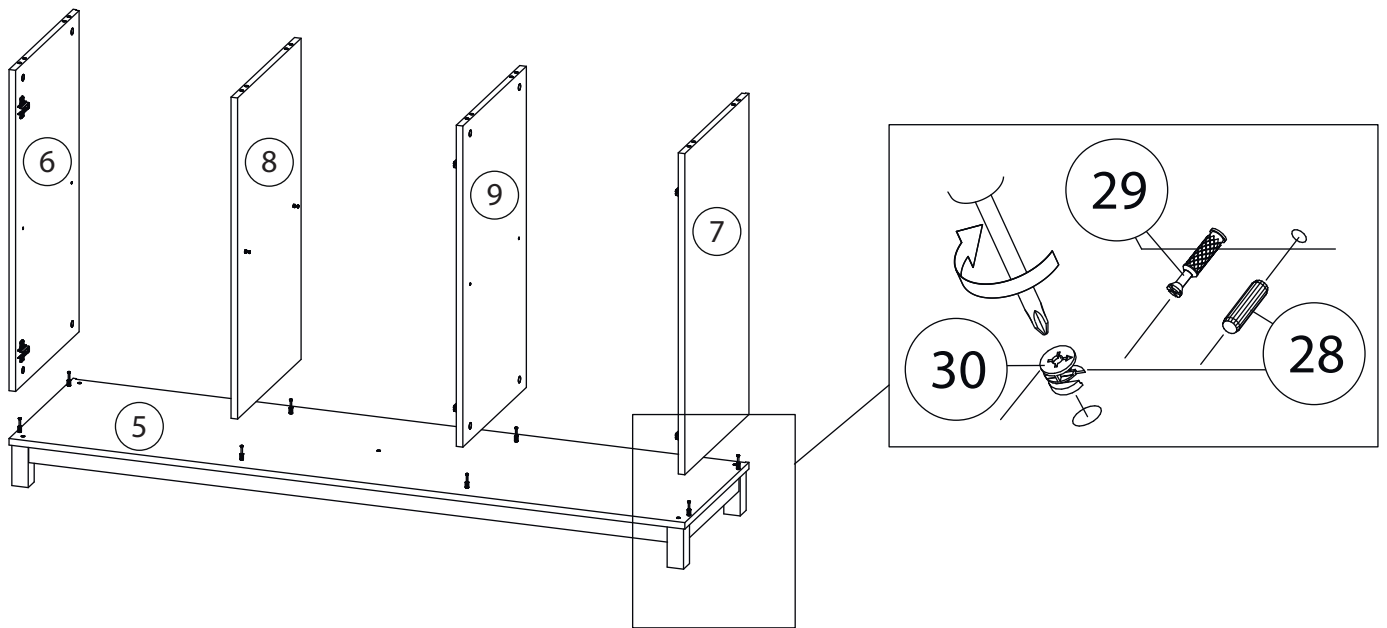

14

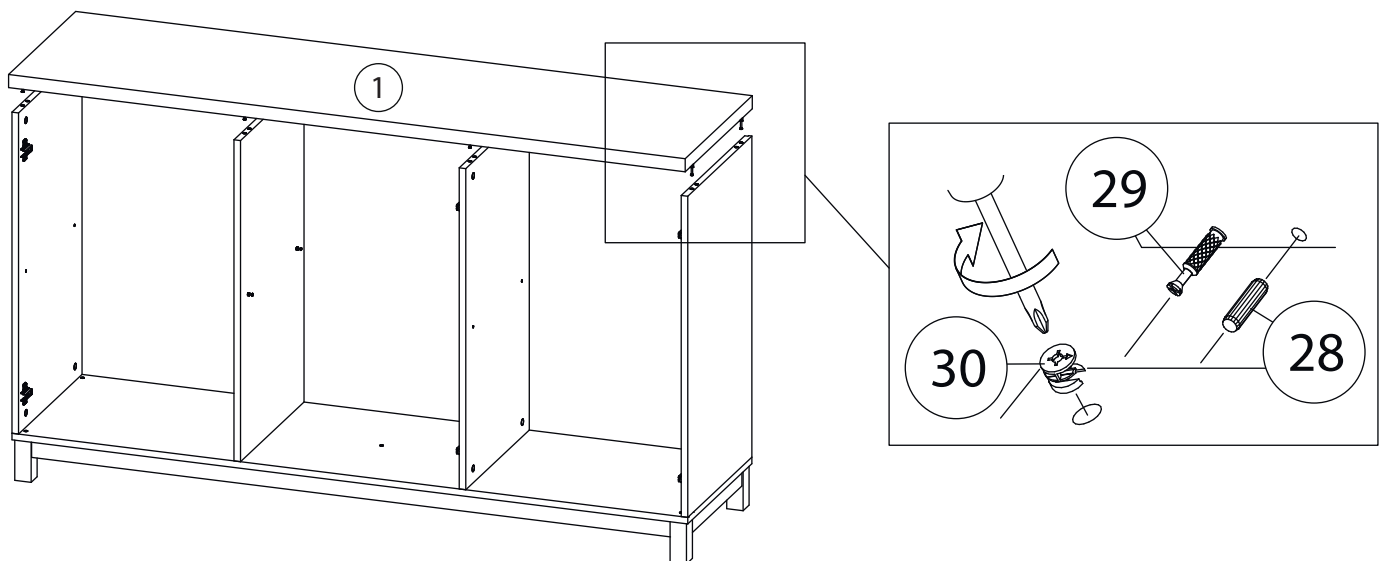

15

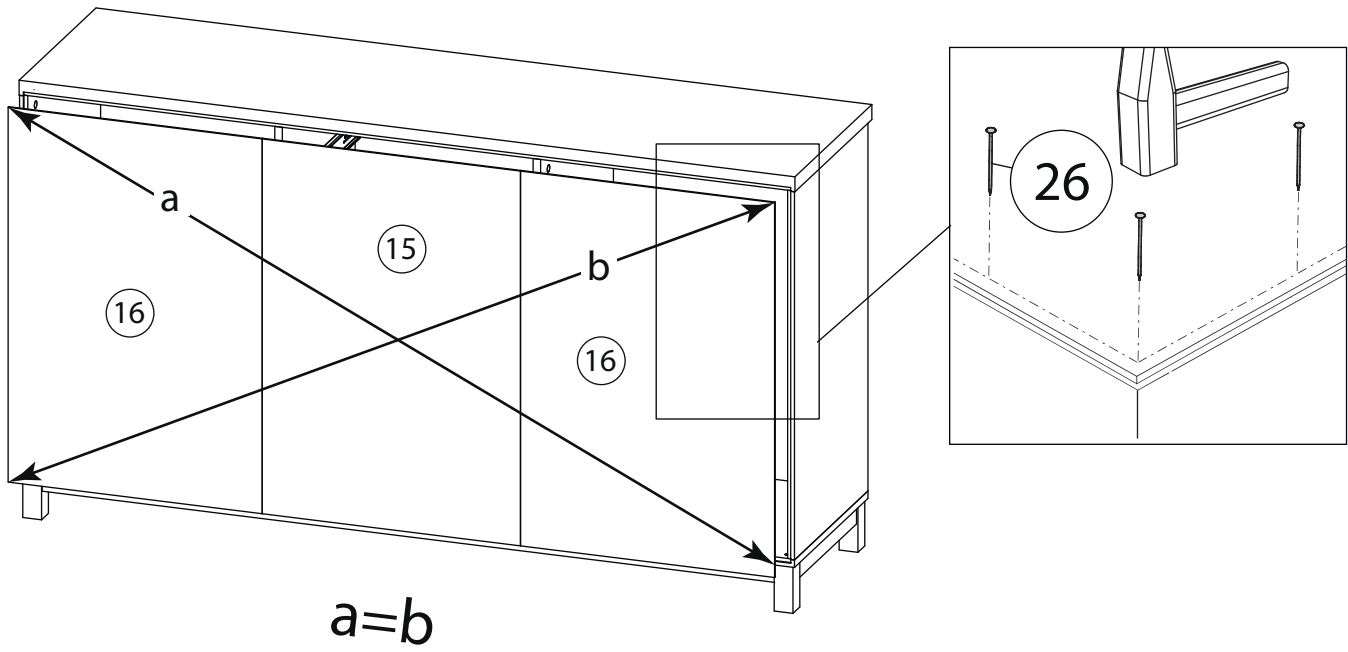

16

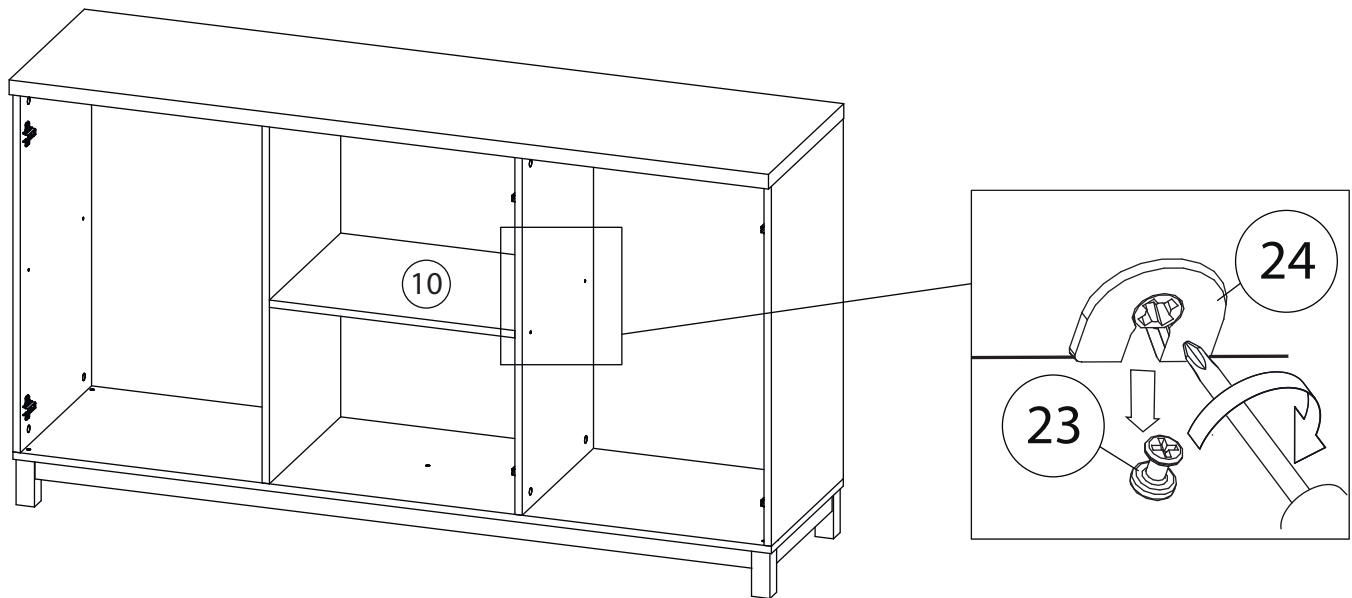

17

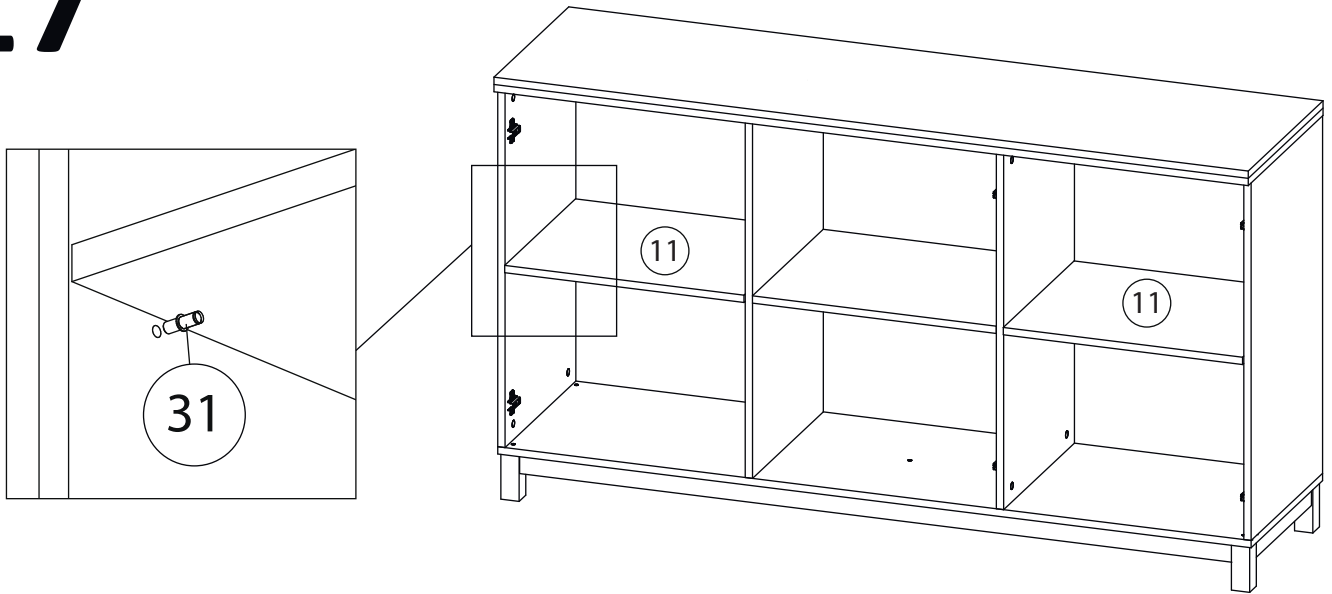

18

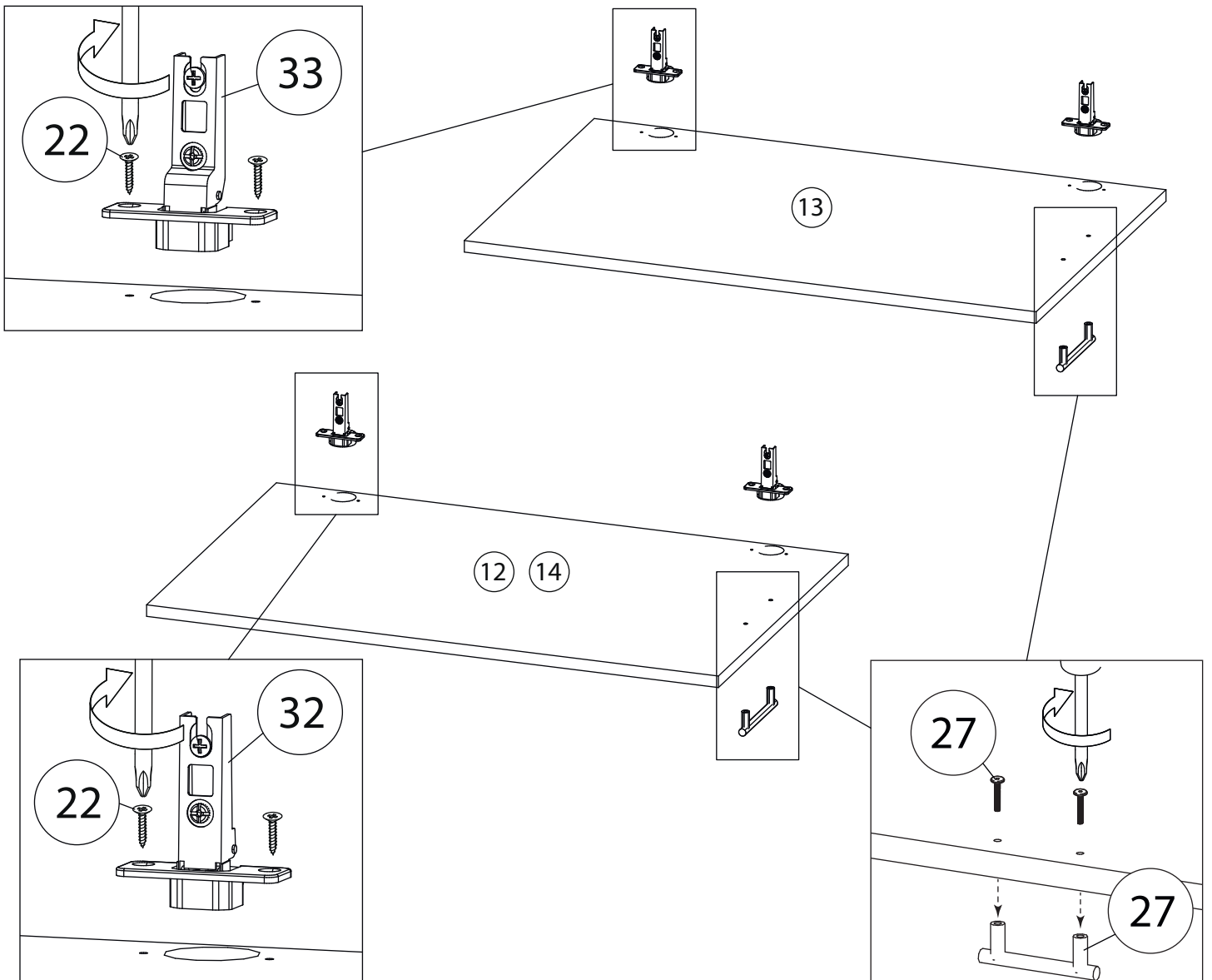

19

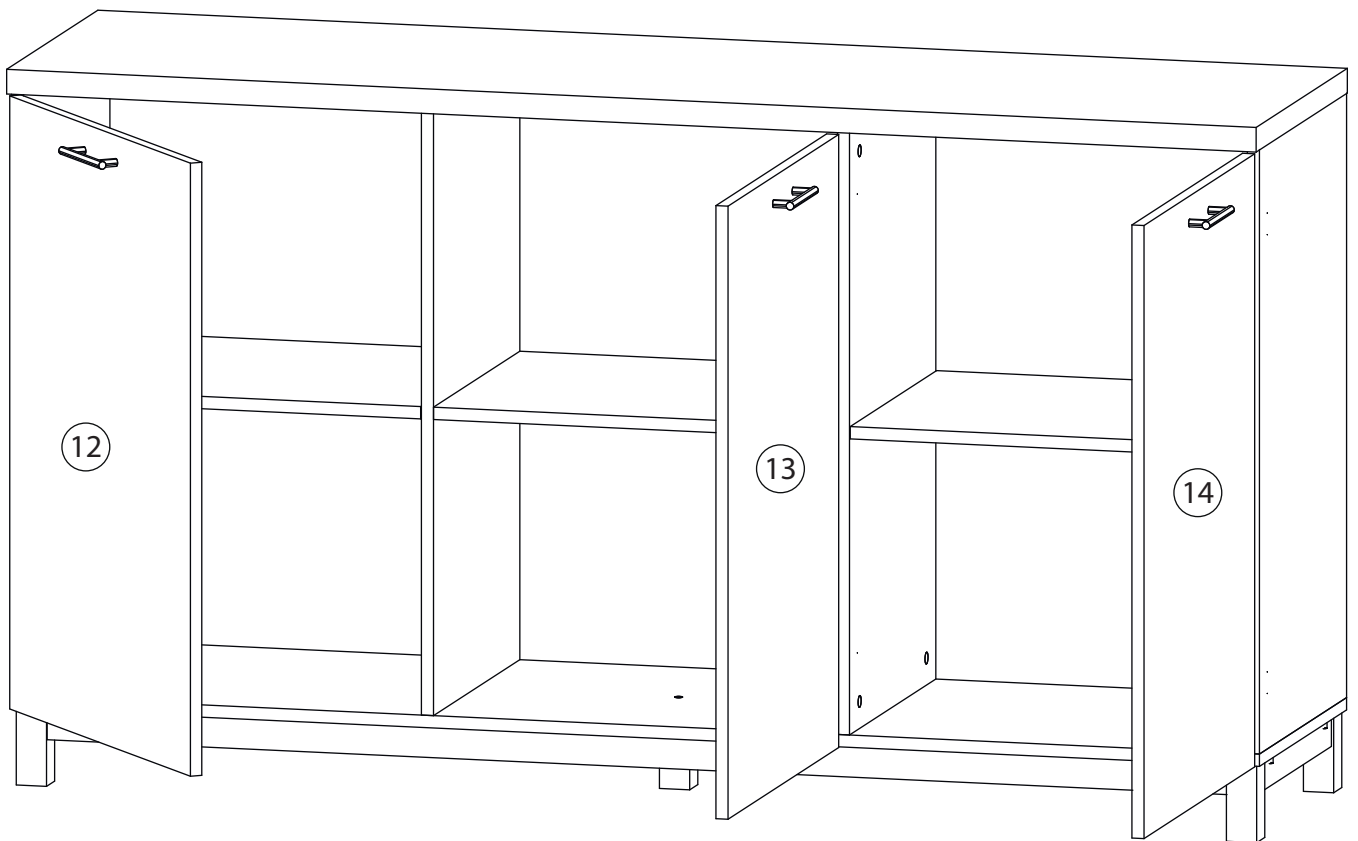

Заклеить технические отверстия заглушками.

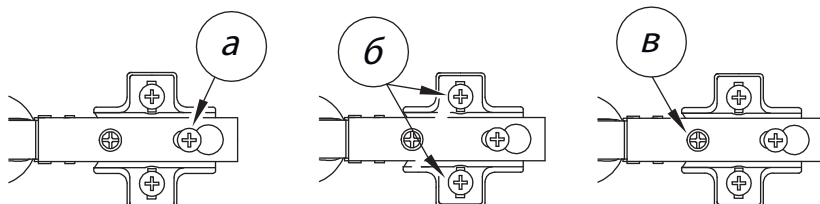

Регулировка петель

а - регулировка расстояния между дверью и корпусом
б - регулировка положения двери по-вертикали
в - регулировка положения ТТдвери по-горизонтали