

Инструкция по сборке

Терни

Тумба прикроватная

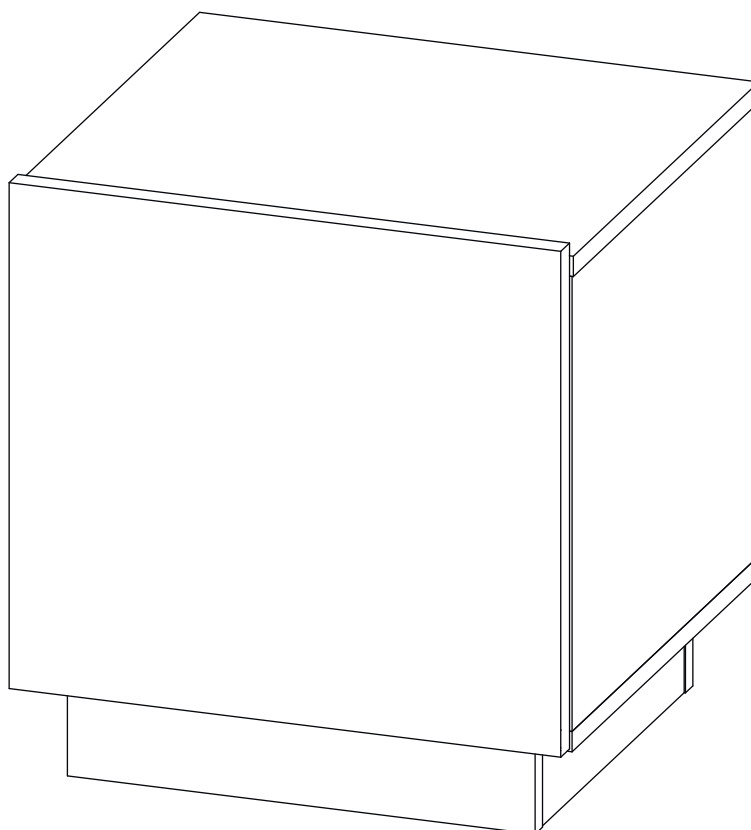

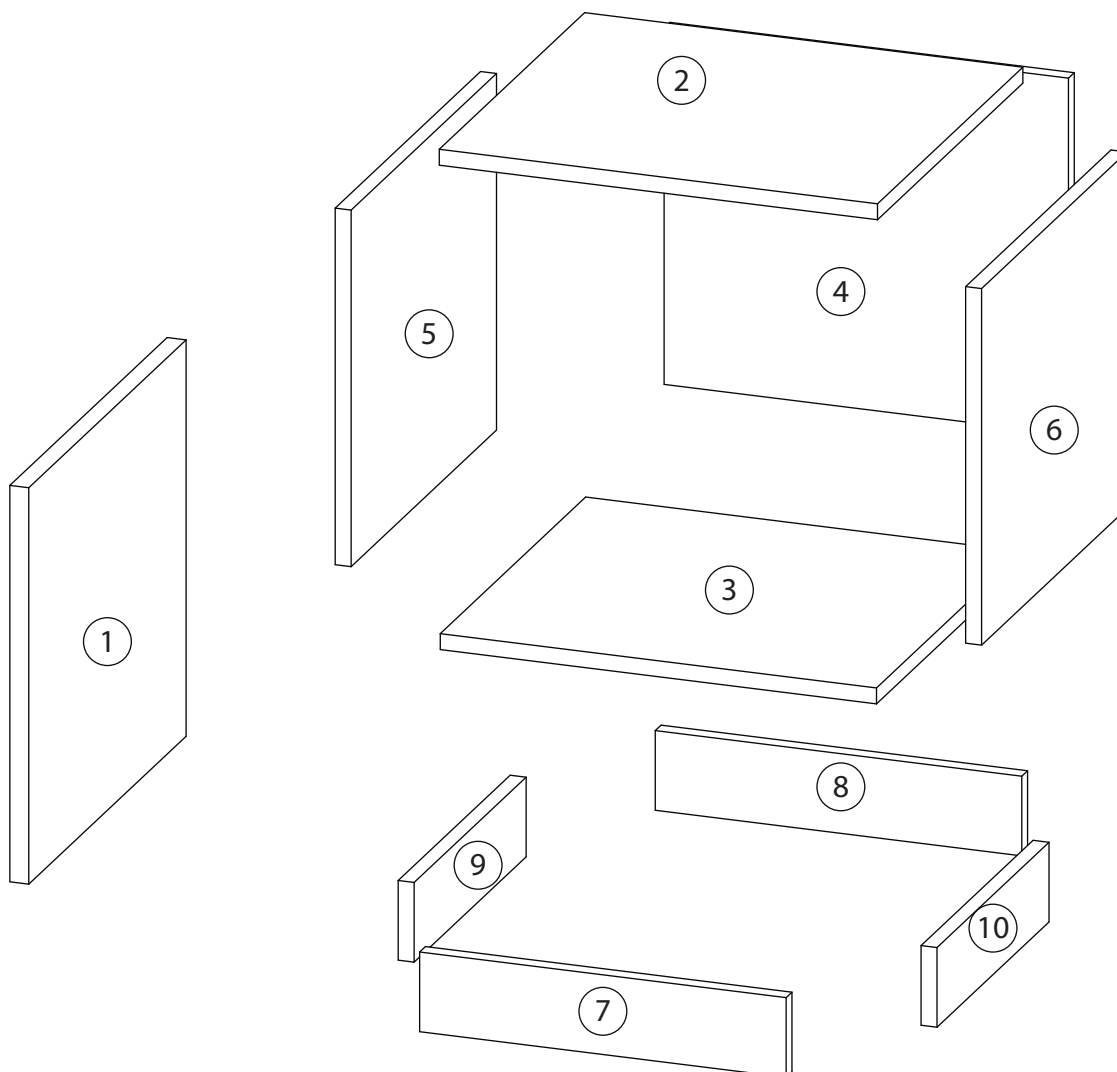

# Детали

Поз.	Наименование	Кол-во	Длина	Ширина
1	Дверь1	1	398	434
2	Крыша	1	440	401
3	Дно	1	438	401
4	Щит ЛДСП	1	358	406
5	Бок левый	1	358	401
6	Бок правый	1	358	401
7	Цоколь	1	368	80
8	Цоколь	1	368	80
9	Цоколь	1	309	80
10	Цоколь	1	309	80

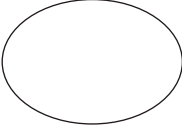
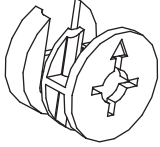

# Фурнитура

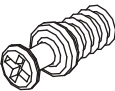
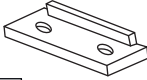
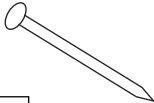
				
11	12	13	14	15
<u>Заглушка</u> <u>Ø13</u>	<u>Заглушка</u> <u>Ø17-20</u>	<u>Евровинт 6,3x13</u>	<u>Евровинт 7x50</u>	<u>Эксцентрик</u>
				
16	17	18	19	20
<u>Саморез 3,5x16</u>	<u>Стяжка VB35</u>	<u>Винт для стяжки</u> <u>VB35</u>	<u>Петля накладная</u>	<u>Подпятник</u>
				
21	22	23	24	
<u>Шкант бук</u>	<u>Шток эксцентрика</u>	<u>Упор-защелка</u> <u>с толкателем</u>	<u>Гвоздь 1,6x25</u>	

# 1

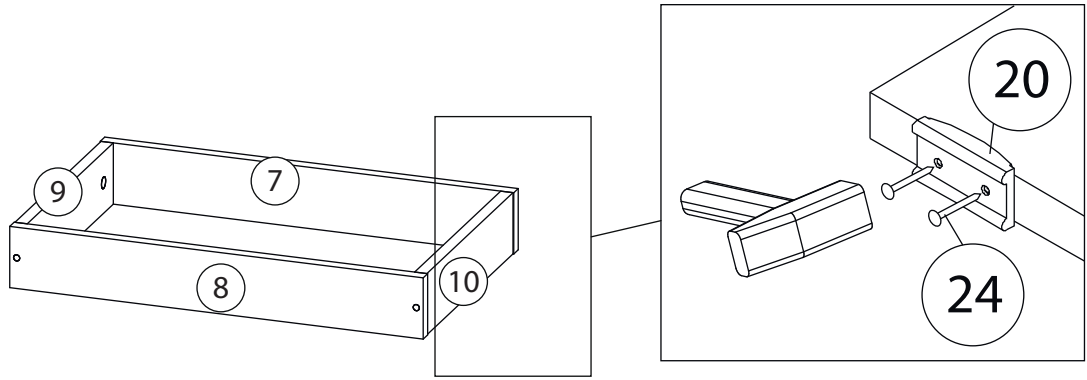

# 2

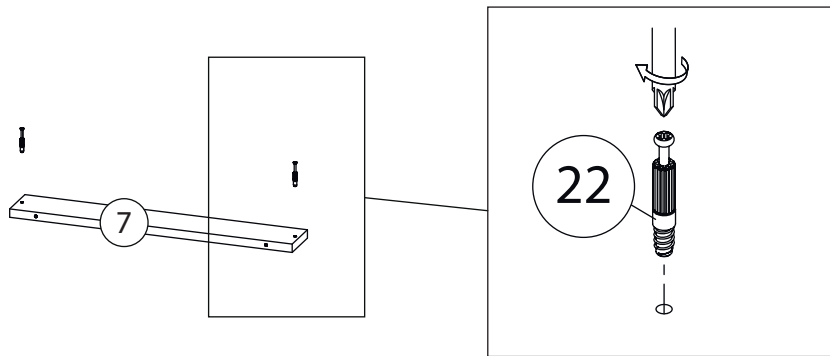

# 3

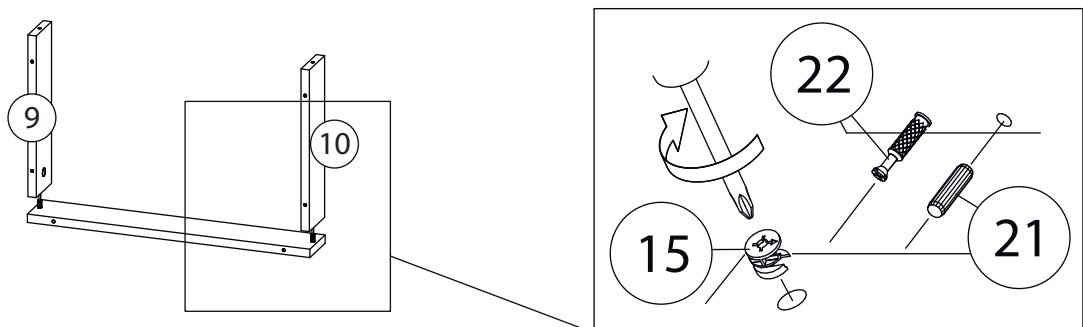

# 4

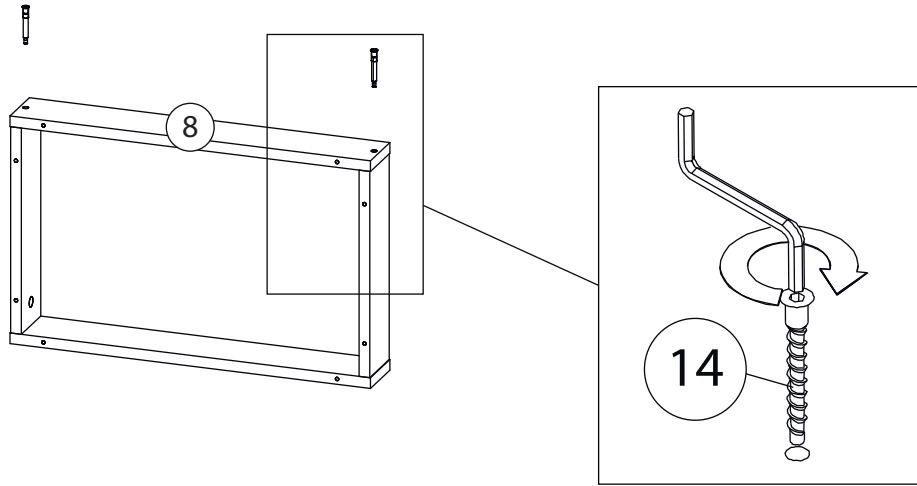

# 5

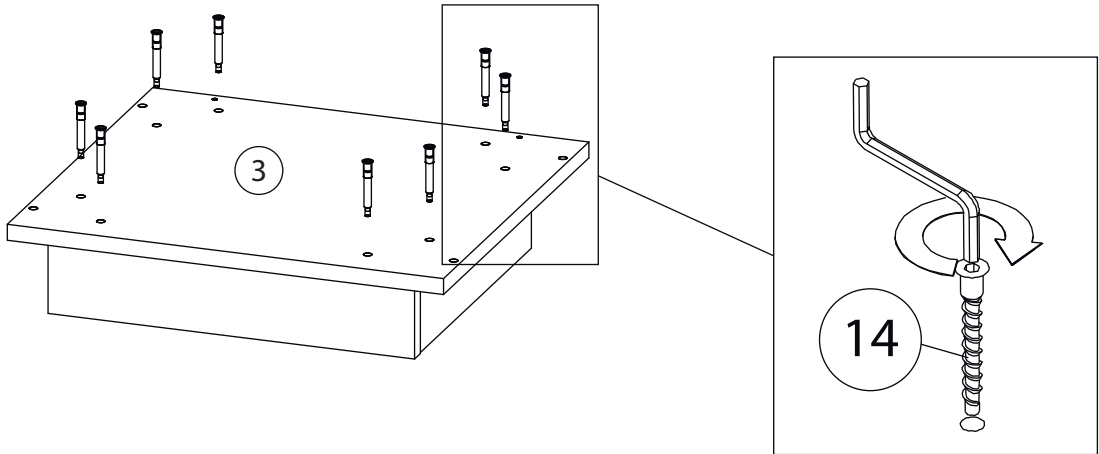

# 6

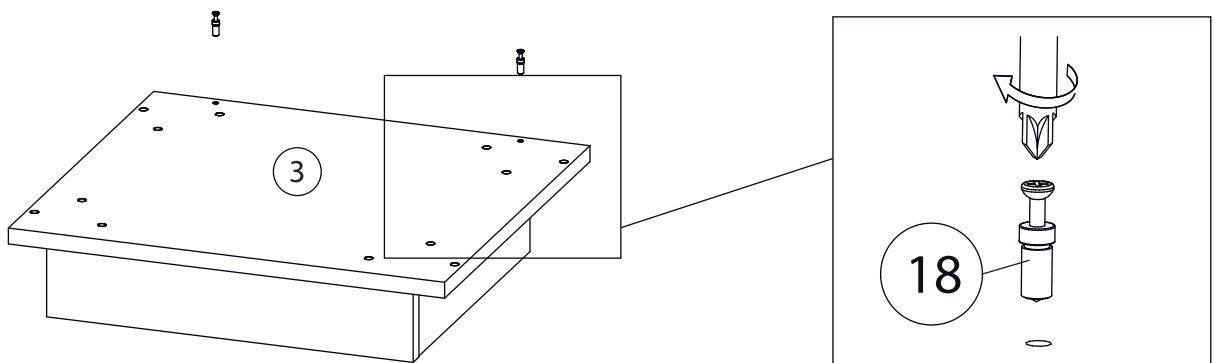

# 7

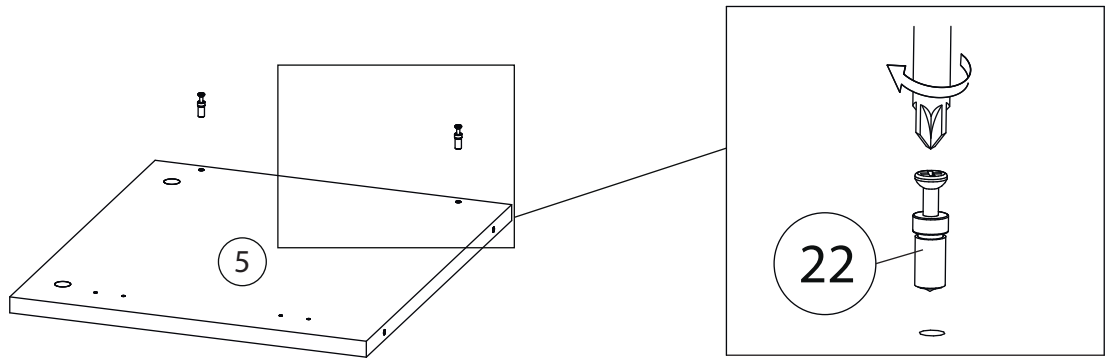

Бок правый ( 6 )  
собирается зеркально

# 8

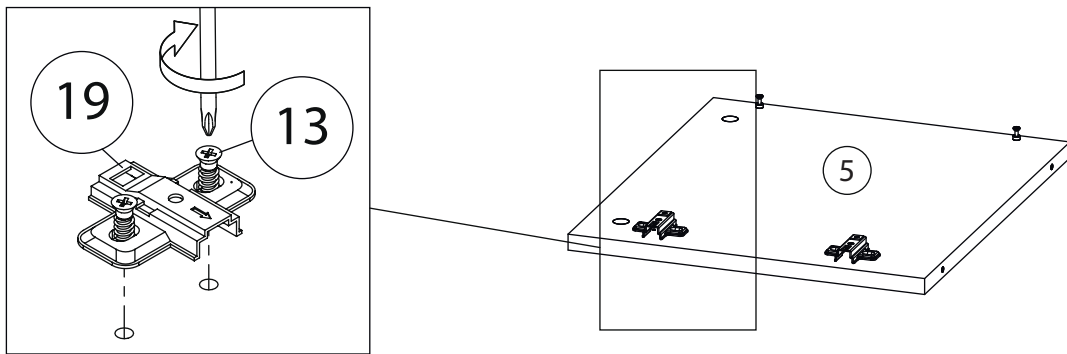

# 9

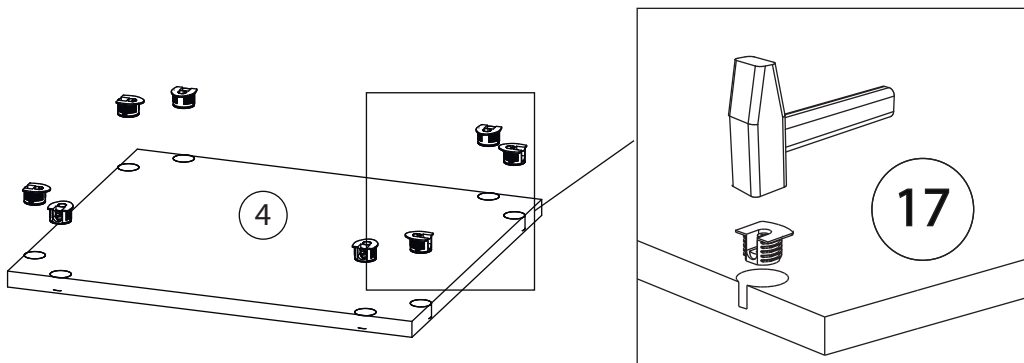

# 10

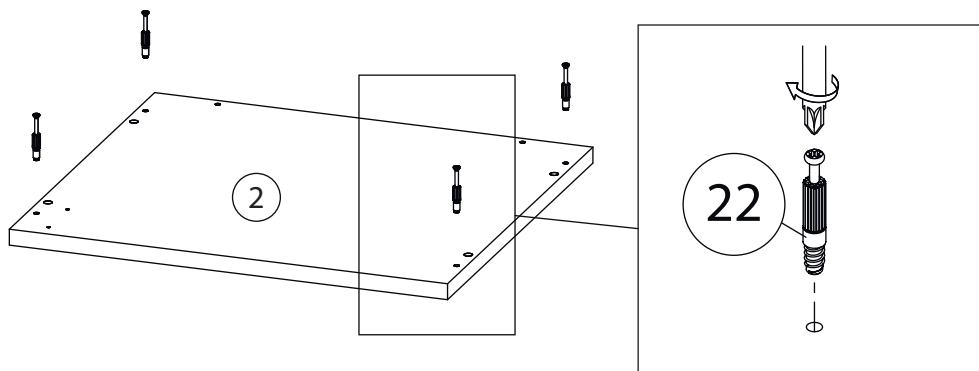

# 11

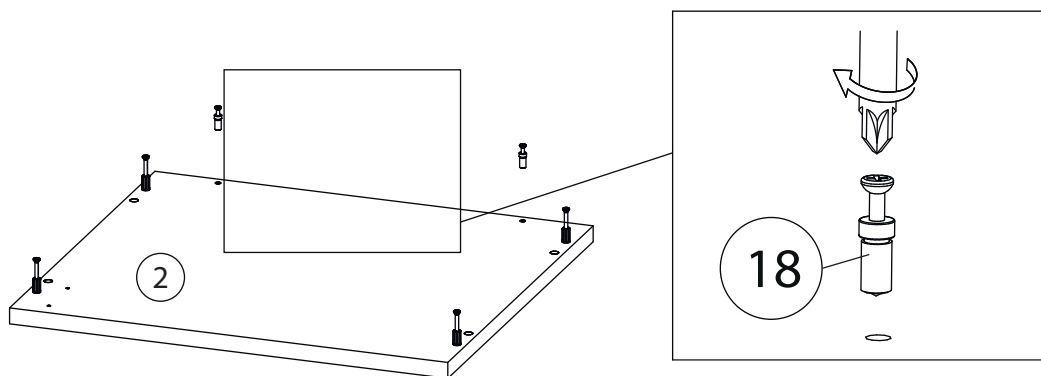

# 12

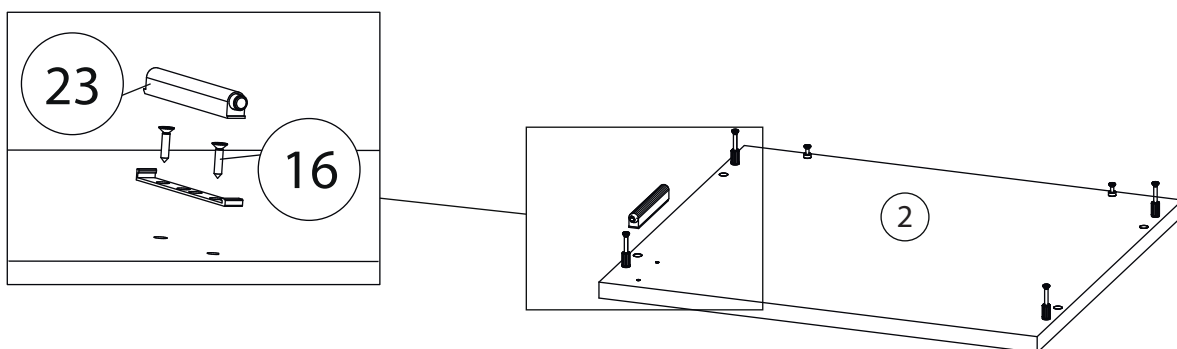

# 13

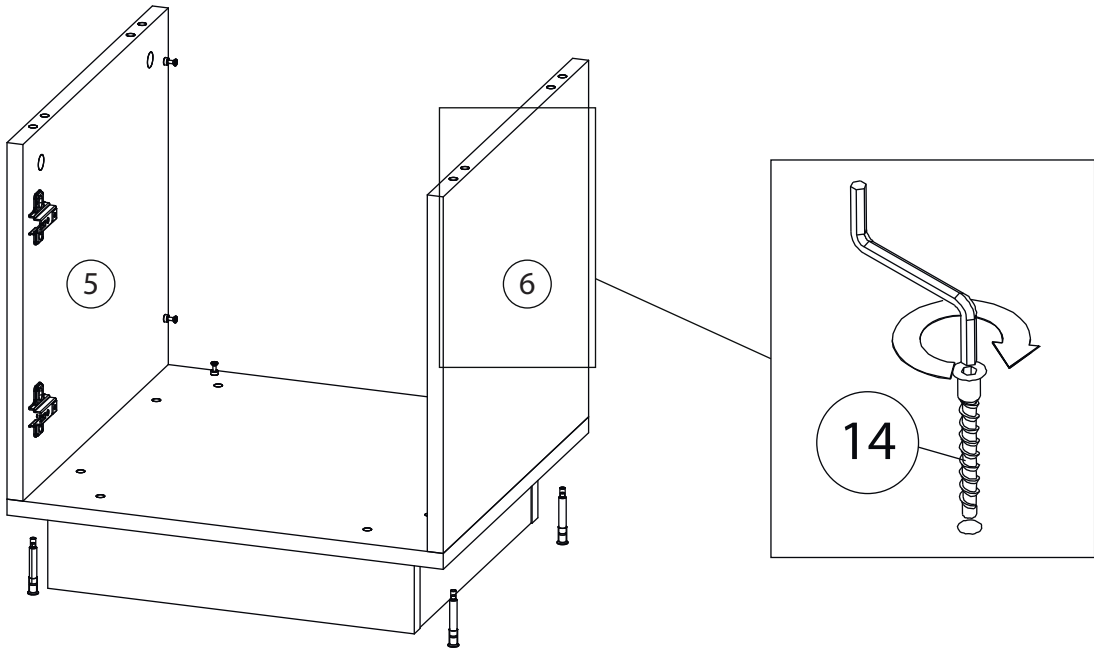

# 15

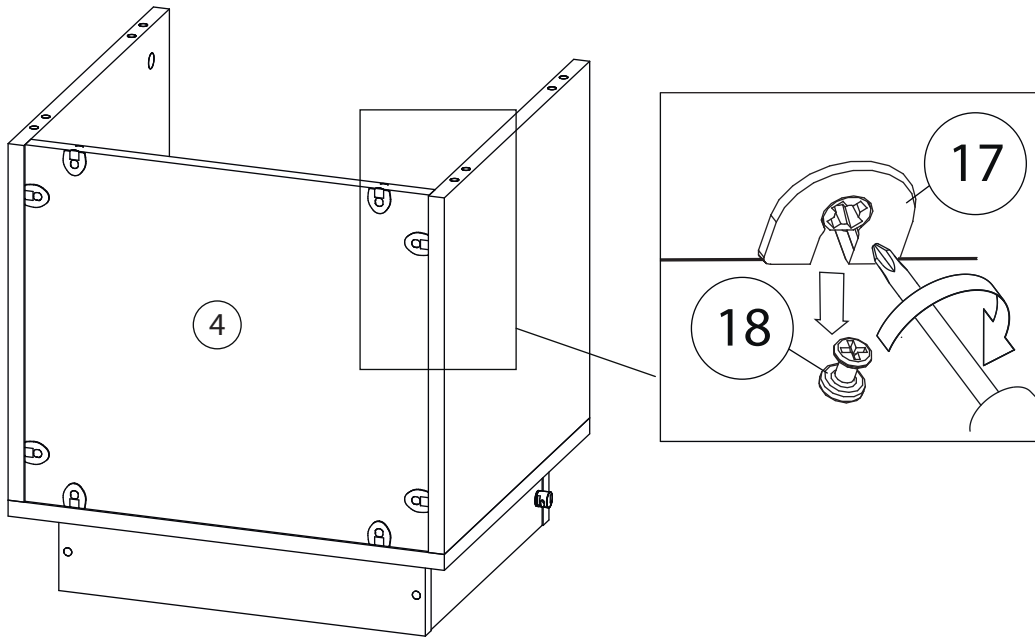

# 16

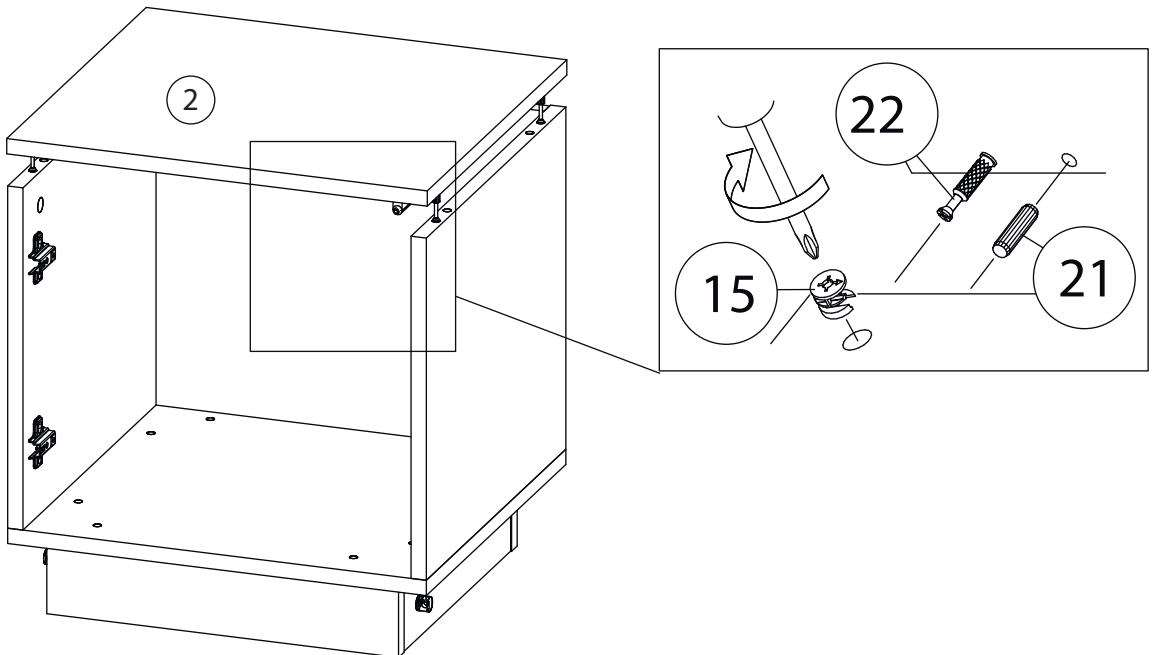

# 17

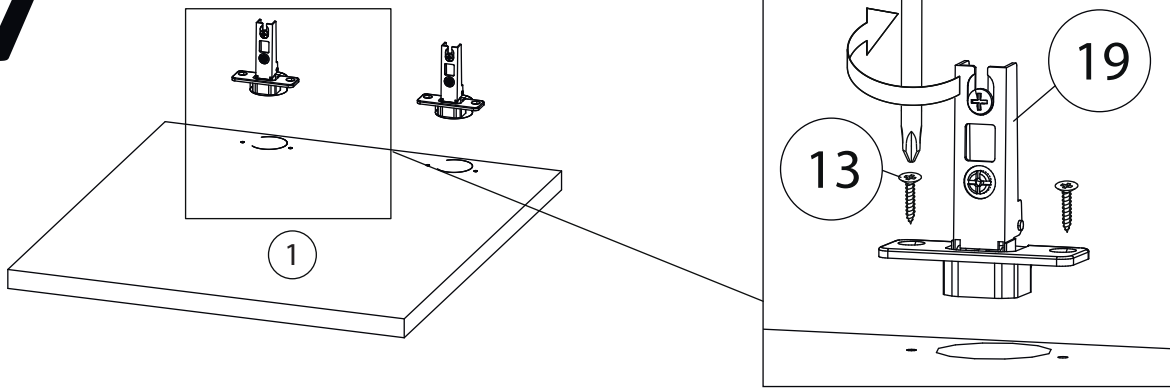

# 18

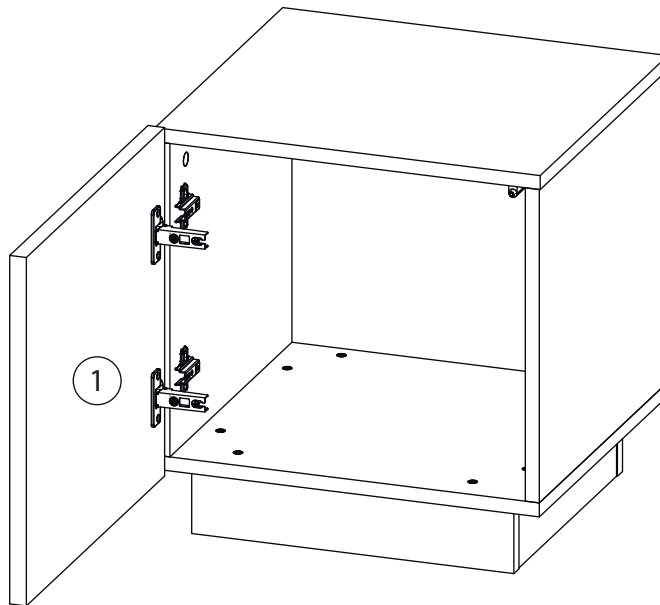

Заклеить технические отверстия заглушками.

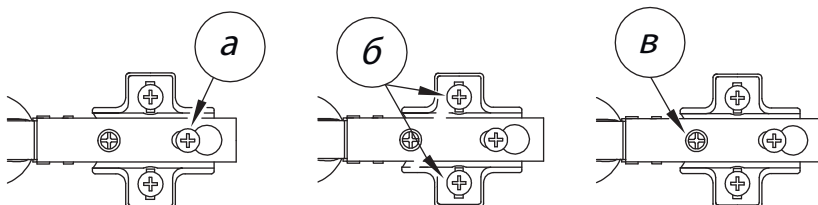

## Регулировка петель

а - регулировка расстояния между дверью и корпусом  
б - регулировка положения двери по-вертикали  
в - регулировка положения двери по-горизонтали